

## BROCHURE SETS



### SINGLE OR DOUBLE SIDED BROCHURE HOLDERS WITH ACRYLIC SHELVES

A brochure holder designed to keep minimum 6 / maximum 32 brochures at the same time in stores, galleries and banks. When used with 4 wheels it is free and mobile. Single or double-faced options are available. Transparent shelves are made of 4 mm acrylic, the legs are made of aluminum.

### KEY SELECTION ATTRIBUTES

- \* Single or Double-sided, free standing Brochure Holders with acrylic shelves for keeping minimum 6 maximum 32 brochures at the same time.
- \* Suitable for INDOOR public spaces with brochure holding capacity of 8x4, 12xA4 and 16xA4 for single sided and 16xA4, 24xA4 and 32xA4 for double sided versions.
- \* One set includes single sided or double sided transparent shelves made of 4mm acrylic, 25x51 mm anodised aluminium profile main body with round corners and 1760 mm height, feet with 450mm length for stability, allen key and 4 bolts for fixing.

- \* When used with 4 wheels it is free and mobile. Wheels are optional, not included in the original package, should be ordered separately.
- \* In case if needed, additional acrylic shelves can be ordered separately.
- \* Natural silver-anodized in standard and various RAL colors available with antimicrobial powder coating.
- \* The product is packed unassembled with an easy-to understand instruction sheet & fixing elements. Shelves are packed separately in a protected box.



## COLOURS IN STOCK



Silver

## SUITABLE FOR

Brochure Sets can be used for INDOOR applications, for displaying brochures in many locations like shopping centers, markets, groceries, hotels, offices airports, shops and stores, hospitals, schools, apartments, restaurants, halls, meeting rooms, gas stations and many more.

## FEATURES

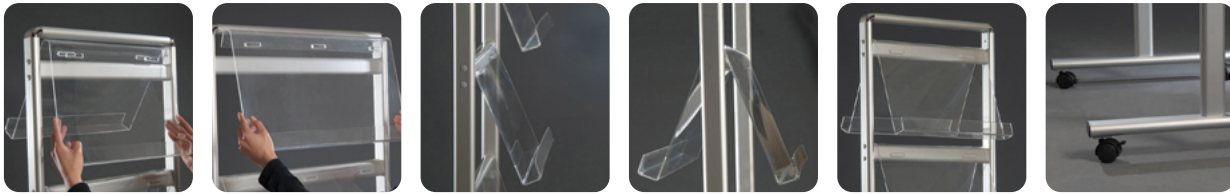

## EXPLODED VIEW

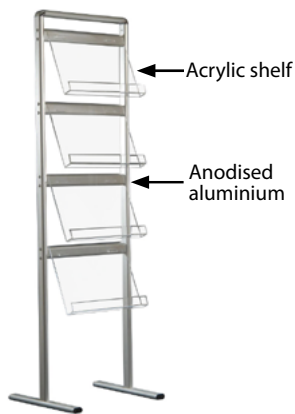

## TECHNICAL DRAWING

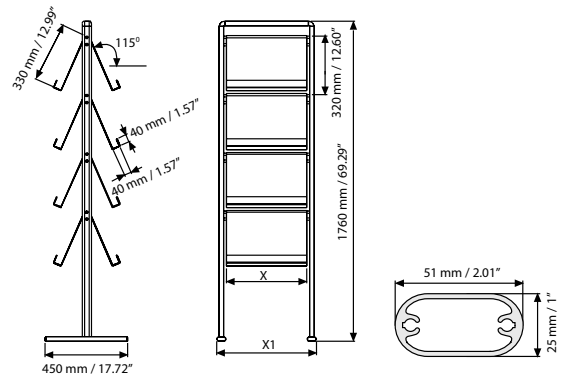

## ARTICLES

ARTICLE	CAPACITY	X	X1	WEIGHT	PACKING SIZE
				WITH PACKING	*W X H X D
UBSSC10N24	16 X A4 double sided	440 mm	546 mm	8,250 kg	560 X 1780 X 80 mm
UBSST10N24	8 X A4 single sided	440 mm	546 mm	12,450 kg	560 X 1780 X 70 mm
UBSSC10N34	24 X A4 double sided	660 mm	766 mm	9,250 kg	780 X 1780 X 80 mm
UBSST10N34	12 X A4 single sided	660 mm	766 mm	15,850 kg	780 X 1780 X 70 mm
UBSSC10N44	32 X A4 double sided	880 mm	986 mm	11,250 kg	1000 X 1780 X 80 mm
UBSST10N44	16 X A4 single sided	880 mm	986 mm	19,400 kg	1000 X 1780 X 70 mm

## OPTIONAL ACCESSORIES

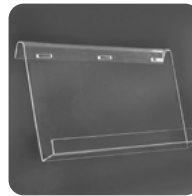

Single sided acrylic shelves for Infoboard and brochure sets.

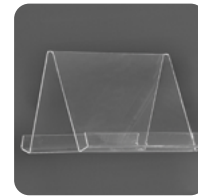

Double sided acrylic shelves for Infoboard and brochure sets.



Wheel for stands. Packed in 1. UYUP444000

ARTICLE	CAPACITY
UYRT0001A4	1X A4
UYRT0002A4	2 X A4
UYRT0003A4	3 X A4
UYRT0004A4	4 X A4

ARTICLE	CAPACITY
UYRC0001A4	1X A4
UYRC0002A4	2 X A4
UYRC0003A4	3 X A4
UYRC0004A4	4 X A4

## PHYSICAL DATA

### Material

Acrylic shelves, 25x51mm aluminium profile main body and feet.

### Surface Finish

Natural silver-anodized in standard and various RAL colors available with antimicrobial powder coating. Call for custom color requests.

### Recycled Content

Up to 78% recycled content used.

### Storage Conditions

Goods should be stored at 0° to 25°C in a dry place. Store in the original package

### Warranty

All products are guaranteed for 3 years by MT Displays with below conditions:

[Warranty Conditions](#)

### Installation Considerations

Brochure sets are packed unassembled with an easy-to understand instruction sheet & fixing elements. Shelves are packed separately in a protected box. One set includes single sided or double sided transparent shelves made of 4mm acrylic, 25x51 mm anodised aluminium profile main body with round corners and 1760 mm height, feet with 450mm length for stability, allen key and 4 bolts for fixing. When used with 4 wheels it is mobile. Wheels are optional, not included in the original package, should be ordered separately. In case if needed, additional acrylic shelves can be ordered separately.

### Design Considerations

Single or Double-sided, free standing Brochure Holders with acrylic shelves for keeping minimum 6 maximum 32 brochures at the same time. Suitable for INDOOR public spaces with brochure holding capacity of 8xA4, 12xA4 and 16xA4 for single sided and 16xA4, 24xA4 and 32xA4 for double sided versions. Long feet provides stability.

### Cleaning and Disinfecting

Clean your displays, with damp microfiber clothes, rinsed with simply water or warm, soapy or gentle shampooed water. Avoid using vinegar, abrasive, acidic, alcohol-based or heavy cleaners or cleaners containing Ammonia. Only after cleaning the product, if needed, simply apply disinfectant or sanitizer that is in compliance with your local guidelines and regulations.



T: +90 850 433 67 85 / info@mtdisplays.com / www.mtdisplays.com

# INSTALLATION INSTRUCTIONS

Brochure Sets / 1001917

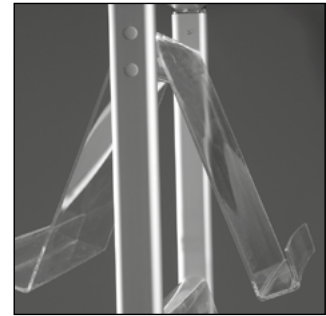
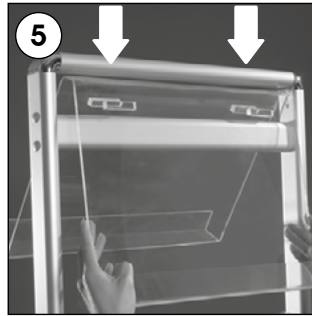
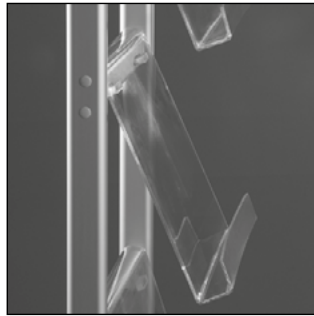
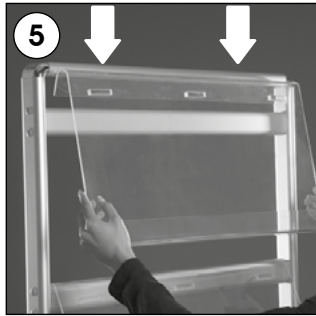
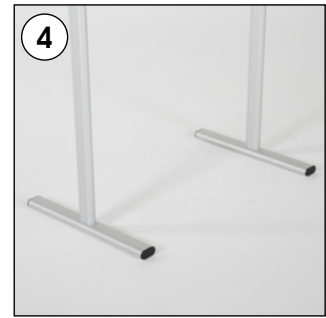
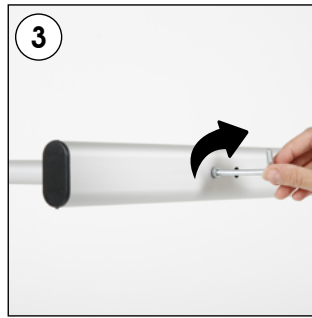
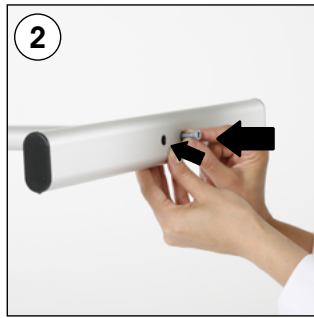
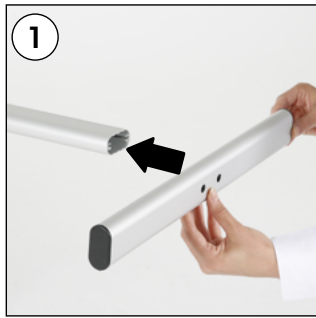

Single sided shelves

Double sided shelves

## Each product package includes mounting accessories

- 1 x Brochure set main body
- 2 x Base profile
- 1 x 5 allen key
- 4 x Bolt 3,5x9,5 mm
- 4 x Acrylic shelf

- Please inform the order number on the product or on the carton (e.g. 1/110001394-460) to the place that you have made the purchase if any problem with the product occurs.
- All rights reserved. All pictures, figures and writings are secured internationally by copy-right law. Infringements will be sued by civil and legal law.



This technical sheet's contents are all subject to update and modification at MT Displays' exclusive discretion. There is nothing official about this document. For final and legally binding information, please get in touch with the sales staff at MT Displays.



T: +90 850 433 67 85 / info@mtdisplays.com / www.mtdisplays.com