

FOLDABLE WOOD COUNTER 2x A4



COUNTERS WITH LOCKABLE ZICK-ZACK BROCHURE HOLDERS

Foldable Wood Counter has 2x A4 capacity. Shelf carrying capacity is 3 kg. It has black body&black top, black body&dark wood top, silver body&black top, silver body&dark wood top, white body&dark wood top options. Its heavy steel base provides durability. Foldable flat design provides space saving and easy transportation. Locking system ensure safe use. Black carry bag is optional. It is very practical to set up in few seconds, by lifting up the brochure holders and locking the system at the bottom and top as well.

KEY SELECTION ATTRIBUTES

- * Free standing, OUTDOOR FRIENDLY, Wood Counter with foldable, single sided zick-zack brochure shelves for keeping minimum 6 brochures at the same time.
- * Practical and smart for mobile presentations and events. Folds flat for saving space and easy transportation. Locking system ensures safe use.
- * Suitable for public spaces with brochure holding capacity of 3 shelves x 2x A4 in standard.
- * One set includes 520x400mm dark wood, black or white coloured hard top with 18mm thickness, 520x400mm black, white or silver powder coated heavy steel base with 25 mm thickness and locking mechanism, black, white or silver powder coated sheet metal foldable shelves with 467mm width and carrying handle for easy transport.
- * Very practical to set up in a few seconds, by lifting up the brochure holders and locking the system at the bottom and top as well. 156mm height when folded, 937mm height when set up and locked.
- * Heavy steel base and lockable system provides stability. Product weight is 12,0 kg. Shelf carrying capacity is 3,0 kg.
- * Black carry bag is optional. Product comes with or without a textile transportation bag.
- * Dark wood top, black metal shelves and steel base; dark wood top, silver metal shelves and steel base; dark wood top and white metal shelves and steel base; black top, black metal shelves and steel base or black top, silver metal shelves and steel base options in standard and various RAL colors available with antimicrobial powder coating.
- * Foldable Wood Counter is packed assembled and folded in a single box. No tool assembly, easy to build-up & ready to use. Set up in 60 seconds.



COLOURS IN STOCK



Silver Black White

SUITABLE FOR

Foldable Wood Counters can be used for OUTDOOR FRIENDLY applications for displaying brochures in many locations like shopping centers, markets, groceries, hotels, offices airports, shops and stores, hospitals, schools, apartments, restaurants, halls, meeting rooms, gas stations and many more.

WATCH VIDEO



Watch video at our website www.mtdisplays.com

FEATURES



Carrying handle



Lock



Lock

EXPLODED VIEW

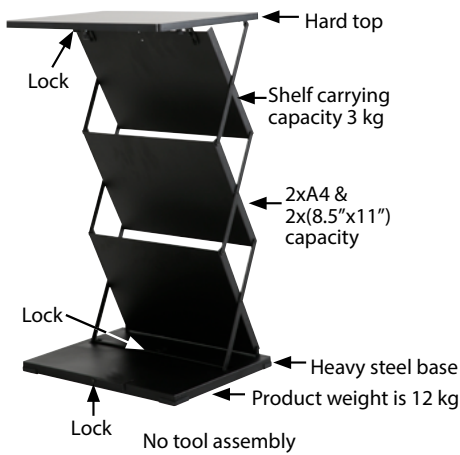

TECHNICAL DRAWING

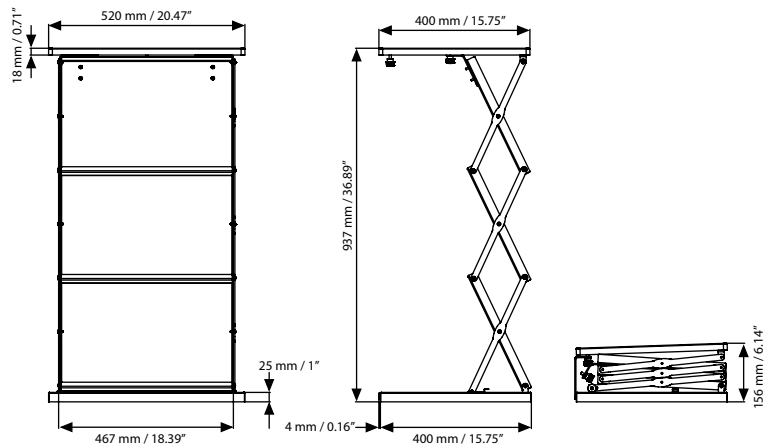

ARTICLES

ARTICLE	CAPACITY	DESCRIPTION	WEIGHT	PACKING SIZE
			WITH PACKING	*W X H X D
UWFC1B0324	2 X A4 - 8.5" X 11"	Black body - Black top	13,530 kg	430 X 560 X 150 mm
UWFC1B1324	2 X A4 - 8.5" X 11"	Black body - Black top with bag	14,000 kg	450 X 580 X 160 mm
UWFC1D0324	2 X A4 - 8.5" X 11"	Black body - Dark wood top	13,530 kg	430 X 560 X 150 mm
UWFC1D1324	2 X A4 - 8.5" X 11"	Black body - Dark wood top with bag	14,000 kg	450 X 580 X 160 mm
UWFC2B0324	2 X A4 - 8.5" X 11"	Silver body - Black top	13,530 kg	430 X 560 X 150 mm
UWFC2B1324	2 X A4 - 8.5" X 11"	Silver body - Black top with bag	14,000 kg	450 X 580 X 160 mm
UWFC2D0324	2 X A4 - 8.5" X 11"	Silver body - Dark wood top	13,530 kg	430 X 560 X 150 mm
UWFC2D1324	2 X A4 - 8.5" X 11"	Silver body - Dark wood top with bag	14,000 kg	450 X 580 X 160 mm
UWFC3W0324	2 X A4 - 8.5" X 11"	White body - Dark wood top	13,530 kg	430 X 560 X 150 mm
UWFC3W1324	2 X A4 - 8.5" X 11"	White body - Dark wood top with bag	14,000 kg	450 X 580 X 160 mm

OPTIONAL ACCESSORIES



Black carry bag



T: +90 850 433 67 85 / info@mtdisplays.com / www.mtdisplays.com

PHYSICAL DATA

Material

Wood top, perforated sheet metal shelves and heavy steel base.

Surface Finish

Dark wood top, black metal shelves and steel base; dark wood top, silver metal shelves and steel base; dark wood top and white metal shelves and steel base; black top, black metal shelves and steel base or black top, silver metal shelves and steel base options in standard and various RAL colors available with antimicrobial powder coating. Call for custom color requests.

Recycled Content

Up to 78% recycled content used.

Warranty

All products are guaranteed for 3 years by MT Displays with below conditions:

[Warranty Conditions](#)

Installation Considerations

Foldable Wood Counter is packed assembled and folded in a single box. No tool assembly, easy to build-up & ready to use. Set up in 60 seconds. One set includes 520x400mm dark wood, black or white colored hard top with 18mm thickness, 520x400mm black, white or silver powder coated heavy steel base with 25 mm thickness and locking mechanism, black, white or silver powder coated sheet metal foldable shelves with 467mm width and carrying handle for easy transport. Very practical to set up in a few seconds, by lifting up the brochure holders and locking the system at the bottom and top as well. 156mm height when folded, 937mm height when set up and locked. Heavy steel base and lockable system provides stability. Product weight is 12,0 kg. Shelf carrying capacity is 3,0 kg. Black carry bag is optional. Product comes with or without a textile transportation bag.

Design Considerations

Free standing, OUTDOOR FRIENDLY, Wood Counter with foldable, single sided zick-zack brochure shelves for keeping minimum 6 brochures at the same time. Practical and smart for mobile presentations and events. Folds flat for saving space and easy transportation. Locking system ensures safe use. Suitable for public spaces with brochure holding capacity of 3 shelves x 2x44 in standard.

Cleaning and Disinfecting

Clean your displays, with damp microfiber clothes, rinsed with simply water or warm, soapy or gentle shampooed water. Avoid using vinegar, abrasive, acidic, alcohol-based or heavy cleaners or cleaners containing Ammonia. Only after cleaning the product, if needed, simply apply disinfectant or sanitizer that is in compliance with your local guidelines and regulations.

INSTALLATION INSTRUCTIONS

Foldable Wood Counter 2x44 - 2x (8.5"x11") / 1011489H000

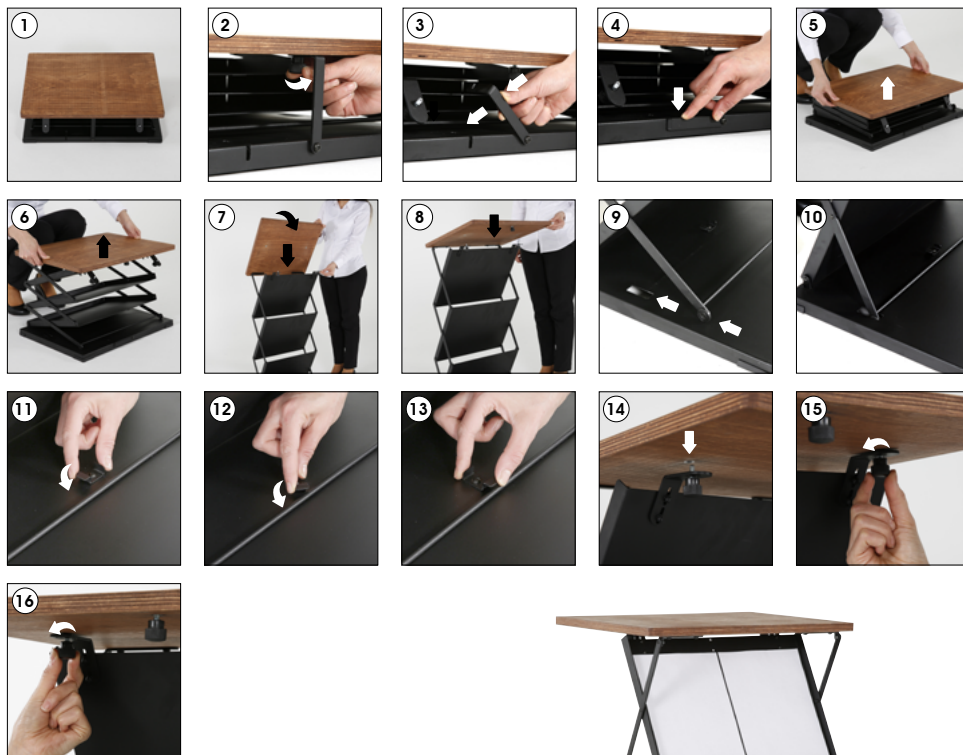

- Please inform the order number on the product or on the carton (e.g. 1/110001394-460) to the place that you have made the purchase if any problem with the product occurs.
- All rights reserved. All pictures, figures and writings are secured internationally by copy-right law. Infringements will be sued by civil and legal law.

This technical sheet's contents are all subject to update and modification at MT Displays' exclusive discretion. There is nothing official about this document. For final and legally binding information, please get in touch with the sales staff at MT Displays.



T: +90 850 433 67 85 / info@mtdisplays.com / www.mtdisplays.com