

## MASTER SIGN FLEX POSTER



### PATENT PROTECTED FLEXIBLE SIDEWALK SIGNS WITH POSTER GRIPPER DESIGN

Made of durable plastic, Master Sign Flex poster is outdoor double sided sign frame which holds two signs in size of 594 X 841 mm. It is built with a molded-in handle for easy transport and available in Beige, Black, Brown and Grey. It has a free space for your logo application at the top. The top side can be used as a handle while transporting. The base and the body are made of weather-resistant HDPE (high-density polyethylene), which makes this sidewalk sign holder ideal for outdoor use.

### KEY SELECTION ATTRIBUTES

- \* Durable plastic Pavement Sign with flex poster and waterbase for resilience and outdoor use.
- \* Patent protected design that takes the attention on the sidewalk and stops passers-by.
- \* Suitable for 594x841mm poster size with max. 2mm thickness, UV resistant anti-glare poster protection with gripper and groove design for easy poster changing.
- \* Weather-resistant: Suitable for rainy conditions with HDPE (high-density polyethylene) body and base.
- \* One set includes a double sided flex poster body with swinging spring, 2

- anti-reflex poster covers, a waterbase with push-up wheels, and 2 nuts for installation.
- \* Optional cable lock kit is available. Should be ordered separately.
- \* The wheels ensure the movement of the unit.
- \* Free space for logo application at the top with 300 x 40 (h) mm print size.
- \* Molded-in handle at top for carrying the product easily.
- \* Natural silver, black, beige, brown in standard and various RAL colors available. Other colors are available upon request.
- \* Packed unassembled with an easy mounting instruction sheet & fixing set. No tools assembly. Set up in 30 seconds. 2 packs.



Beige-Brown



Black-Black



Grey-Black



## COLOURS IN STOCK

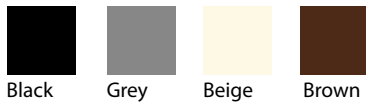

Black Grey Beige Brown

## COLOUR OPTIONS

White - RAL 9003

Black - RAL 9005

Red - RAL 3020

Blue - RAL 5002

Green - RAL 6029

Yellow - RAL 1021

## SUITABLE FOR

Master Sign Flex Posters can be used for INDOOR and OUTDOOR applications, for signage needs in many locations like shopping centers, markets, groceries, hotels, offices airports, shops and stores, hospitals, schools and many more.

## WATCH VIDEO



Watch video at our website  
www.mtdisplays.com

## FEATURES



No tools assembly

## EXPLODED VIEW



## TECHNICAL DRAWING

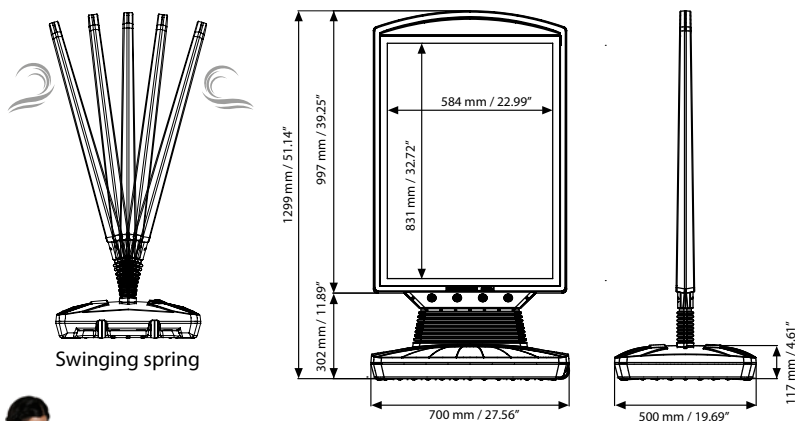

## ARTICLES

ARTICLE	SIZE	COPY SIZE	DESCRIPTION	WEIGHT	PACKING SIZE
				WITH PACKING	*W X H X D
UPFS3100A1	594 X 841 mm	584 X 831 mm	Silver- Black	15,000 kg	700 X 1260 X 75 / 530 X 740 X 135 mm
UPFS3200A1	594 X 841 mm	584 X 831 mm	Beige - Brown	15,000 kg	700 X 1260 X 75 / 530 X 740 X 135 mm
UPFS3300A1	594 X 841 mm	584 X 831 mm	Black - Black	15,000 kg	700 X 1260 X 75 / 530 X 740 X 135 mm

## OPTIONAL ACCESSORIES

Cable lock kit 2100 mm / TZZZ998701



Easy to carry  
Product weight 12 kg.

## PHYSICAL DATA

### Material

Durable plastic - HDPE (high-density polyethylene) flex board body and waterbase with  $\pm 1,5$ mm shrinking tolerance, and UV resistant anti-glare poster protection.

### Poster Material & Thickness

0,10 - 0,20 mm for standard product. Max poster thickness is 2 mm. Any non-standard poster thicknesses should be indicated with order. Max. poster thickness is 2mm.

### Surface Finish

Natural silver, black, beige and brown in standard and various RAL colors available. Other colors are available upon request.

### Recycled Content

Up to 40% recycled content used.

### Warranty

All products are guaranteed for 3 years by MT Displays with below conditions:

[Warranty Conditions](#)

### Installation Considerations

Packed unassembled with an easy mounting instruction sheet & fixing set. Set up in 30 seconds. No tools assembly. 2 packs. One set includes a double sided flex poster body with swinging spring design, 2 anti-reflex poster covers, a waterbase with push-up wheels, 2 nuts for installation. Optional cable lock kit is available. Should be ordered separately.

### Storage Conditions

Goods should be stored at 0° to 25°C in a dry place. Store in the original package.

### Design Considerations

Durable plastic Pavement Sign with flex poster and waterbase for resilience and outdoor use. Patent protected design that takes the attention on the sidewalk and stops passers-by. Suitable for 594x841 mm poster size with max. 2mm thickness, UV resistant anti-glare poster protection with gripper and groove design for easy poster changing. Weather-resistant: Suitable for rainy conditions with HDPE (high-density polyethylene)

body and base. The push-up wheels ensure the movement of the unit. Suitable for silk screen printing, free space for logo application at the top with 300 x 40 (h) mm print size. Molded-in handle at top for carrying the product easily. 12kg product weight.

### Cleaning and Disinfecting

Clean your displays, with damp microfiber clothes, rinsed with simply water or warm, soapy or gentle shampooed water. Avoid using vinegar, abrasive, acidic, alcohol-based or heavy cleaners or cleaners containing Ammonia. Only after cleaning the product, if needed, simply apply disinfectant or sanitizer that is in compliance with your local guidelines and regulations.

### Patent

Patented product.



T: +90 850 433 67 85 / info@mtdisplays.com / www.mtdisplays.com

# PRINT TEMPLATES

## Master Sign Flex Poster - A1

Document Size: 604 x 851 mm (Includes Bleeds)

Finished Size: 594 x 841 mm [Print](#)

# INSTALLATION INSTRUCTIONS

## Master Sign Flex Poster / 1011861H000

### Each product includes

- 1 x Waterbase
- 1 x Flex Poster
- 2 x Nut

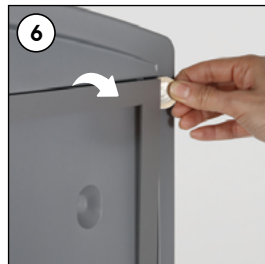
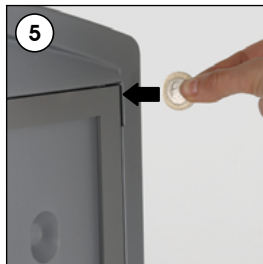
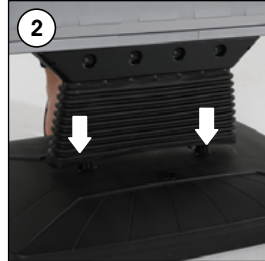
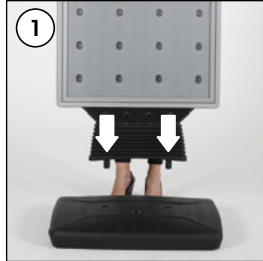

Easy to carry

- Please inform the order number on the product or on the carton (e.g. 1/110001394-460) to the place that you have made the purchase if any problem with the product occurs.
- All rights reserved. All pictures, figures and writings are secured internationally by copy-right law. Infringements will be sued by civil and legal law.

This technical sheet's contents are all subject to update and modification at MT Displays' exclusive discretion. There is nothing official about this document. For final and legally binding information, please get in touch with the sales staff at MT Displays.



T: +90 850 433 67 85 / [info@mtdisplays.com](mailto:info@mtdisplays.com) / [www.mtdisplays.com](http://www.mtdisplays.com)