

## WATERBASE PAVEMENT SIGNS



### FILLABLE SIDEWALK SIGNS, MADE OF DURABLE PLASTIC

Stable, heavy and enduring pavement sign. Suitable to set aside in parking areas, play grounds, shop entrances and busy pavement roads; especially for windy areas. Standard in metallic RAL 9006 color. By opening the plastic stoppers, you can pour in either water or sand to make the stand heavier.

### KEY SELECTION ATTRIBUTES

- \* Double-sided Pavement Signs with two durable plastic design options: Pyramid and A Board Models.
- \* Pyramid Signs are composed of three parts made of (HDPE) durable plastic: (1) top with double-sided self-adhesive poster area and lifting handle, (2) body and (3) waterfillable base with plastic water cap for filling in with water or sand for keeping the system stable. When attaching the body and top part of Pyramid Sign, press firmly with force.
- \* For A Board model, one set includes double sided (HDPE) durable plastic boards with self-adhesive poster areas on both sides with a plastic water cap on top for filling in with water or sand for keeping the system stable.
- \* Suitable to set aside in parking areas, play grounds, shop entrances and busy pavement roads; especially for windy areas.
- \* Pyramid Sign model is suitable for outdoor use with 336x387mm self-adhesive posters to stick-on both sides.
- \* A Board Sign model is suitable for outdoor use with 325x570mm self-adhesive posters to stick-on both sides.
- \* Easy to move and store with 5,5 kg product weight for Pyramid Sign model filled in with water. Maximum water capacity for Pyramid Sign is 4,5 liters.
- \* Easy to move and store with 8,0 kg product weight for A Board Sign model filled in with water. Maximum water capacity for A Board Sign is 5,0 liters.
- \* Standard in metallic RAL 9006 color and various RAL colors available upon request.
- \* The product is packed unassembled. No tool assembly. Heavy base provides stability.
- \* Printing area has a  $\pm 1,5$  mm tolerances in size. Stickers are not included in the original box.



Pyramid



A Board



## SUITABLE FOR

Waterbase Pavement Signs can be used for OUTDOOR applications, for signage needs in locations like parking areas, play grounds, shop entrances and busy pavement roads; especially for windy areas and many more.

## WATCH VIDEO



Watch video at our website  
www.mtdisplays.com

## FEATURES



## EXPLODED VIEW



Maximum water capacity is 4,5 liter.

Maximum water capacity is 5 liter.

## TECHNICAL DRAWING

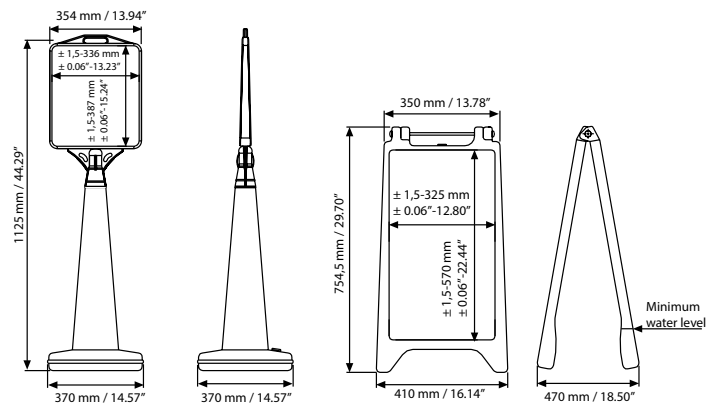

## ARTICLES

| ARTICLE    | MODEL   | WEIGHT with water | WEIGHT       | PACKING SIZE       |
|------------|---------|-------------------|--------------|--------------------|
|            |         |                   | WITH PACKING | *W X H X D         |
| UWPS005000 | Pyramit | 5,5 kg            | 3,565 kg     | 400 X 700 X 400 mm |
| UWPS001000 | A Board | 8 kg              | 3,560 kg     | 420 X 720 X 125 mm |

## PHYSICAL DATA

### Material

Produced using recyclable materials  
High density polyethylene (HDPE).

### Surface Finish

Standard in metallic RAL 9006 color and various RAL colors available upon request. Call for custom color requests.

### Recycled Content

Up to 30% recycled content used.

### Warranty

All products are guaranteed for 2 years by MT Displays with below conditions:  
[Warranty Conditions](#)

### Storage Conditions

Goods should be stored at 0° to 25°C in a dry place. Store in the original package.

### Poster Material

Suitable for self-adhesive posters to stick-on.

### Installation Considerations

Waterbase Pavement Signs are packed unassembled in a single box with an easy-to-understand instruction sheet. No tool assembly. Pyramit Signs are composed of three parts made of (HDPE) durable plastic: (1) top with double-sided self-adhesive poster area and lifting handle, (2) body and (3) waterfillable base with plastic water cap for filling in with water or sand for keeping the system stable. When attaching the body and top part of Pyramit Sign, press firmly with force. For A Board model, one set includes double sided (HDPE) durable plastic boards with self-adhesive poster areas on both sides with a plastic water cap on top for filling in with water or sand for keeping the system stable.

### Design Considerations

Double-sided Pavement Signs with two durable plastic design options: Pyramit and A Board Models. Suitable to set aside in parking areas, play grounds, shop entrances and busy pavement roads; especially for windy areas. Pyramit

Sign model is suitable for outdoor use with 336x387mm self-adhesive posters to stick-on both sides. A Board Sign model is suitable for outdoor use with 325x570mm self-adhesive posters to stick-on both sides. Printing area has a  $\pm 1,5$  mm tolerances in size. Stickers are not included in the original box. Easy to move and store with 5,5 kg product weight for Pyramit Sign model filled in with water. Maximum water capacity for Pyramid Sign is 4,5 liters. Easy to move and store with 8,0 kg product weight for A Board Sign model filled in with water. Maximum water capacity for A Board Sign is 5,0 liters.

### Cleaning and Disinfecting

Clean your displays, with damp microfiber clothes, rinsed with simply water or warm, soapy or gentle shampooed water. Avoid using vinegar, abrasive, acidic, alcohol-based or heavy cleaners or cleaners containing Ammonia. Only after cleaning the product, if needed, simply apply disinfectant or sanitizer that is in compliance with your local guidelines and regulations.



T: +90 850 433 67 85 / info@mtdisplays.com / www.mtdisplays.com

# INSTALLATION INSTRUCTIONS

## Waterbase Pavement Signs Pyramid / 1001890

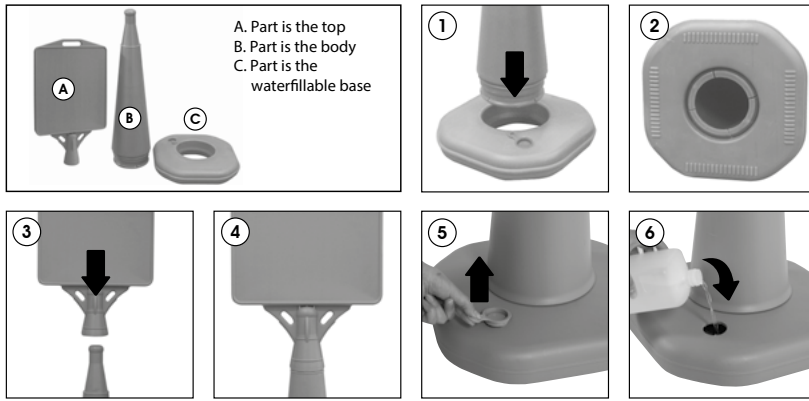

**Caution:** When attaching the body and top part, press firmly with force.



- Please inform the order number on the product or on the carton (e.g. 1/110001394-460) to the place that you have made the purchase if any problem with the product occurs.
- All rights reserved. All pictures, figures and writings are secured internationally by copy-right law. Infringements will be sued by civil and legal law.

## Waterbase Pavement Signs A Board / 1007120

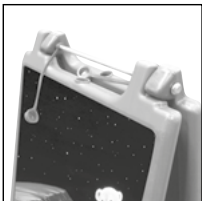

- Please fill in the stand with water through the holes on the top.

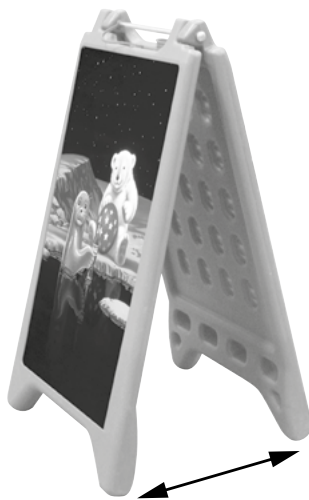

- Please inform the order number on the product or on the carton (e.g. 1/110001394-460) to the place that you have made the purchase if any problem with the product occurs.
- All rights reserved. All pictures, figures and writings are secured internationally by copy-right law. Infringements will be sued by civil and legal law.

This technical sheet's contents are all subject to update and modification at MT Displays' exclusive discretion. There is nothing official about this document. For final and legally binding information, please get in touch with the sales staff at MT Displays.



T: +90 850 433 67 85 / info@mtdisplays.com / www.mtdisplays.com