

WOOD DRY ERASE FLOOR STAND



SOLID WOOD SIDEWALK SIGNS FOR USE WITH MARKERS

Wood Dry Erase Floor Stand is made of fir wood. It has a double sided magnetic and dry-wipe chalkboard surface. It offers a perfect solution where announcements change frequently such as bars, restaurants, hotels and its wooden look creates a friendly atmosphere to your business advertisement. Foldable support can be used on both sides. Chain provides stability. 3 size options are available.

KEY SELECTION ATTRIBUTES

- * Double-sided, free-standing sidewalk signs with foldable support, designed for writing on with waterbase markers.
- * A perfect way to present removable messages, announcements or promotions to your audience while keeping them updated.
- * Suitable for INDOOR use with 440x770mm, 440x1020mm and 440x1370mm writing areas.
- * One set includes a double sided solid fir wood profile frame with lacquered finish for long term use and wood support foldable on both sides, double sided magnetic white dry-wipe chalkboards for changing notes easily, chain for keeping the system stable.
- * Foldable support can be used on both sides. Easy to carry by folding the support, and saving space in storage.
- * Magnetic PET covers and magnetic buttons are optional, not included in standard package. Please order separately.
- * Suitable for using chalkboard water-based pen. Chalkboard pens are not included in the original pack, should be ordered separately. No-ghost after cleaning. For spotless removing of chalk pens from surface, please use window & glass cleaner otherwise clean with damp cloth.
- * Natural fir wood frames with lacquered finish and magnetic white dry-wipe surface in standard.
- * Packed unassembled in a single box with an easy-to-understand instruction sheet. Assembly in 10 seconds.



440x770 mm

440x1020 mm

440x1370 mm



COLOURS IN STOCK



Natural Wood

SUITABLE FOR

Wood Dry Erase Floor Stands can be used for INDOOR applications, for signage needs in many locations like shopping centers, markets, groceries, hotels, offices airports, shops and stores, hospitals, schools, apartments and many more.

FEATURES



EXPLODED VIEW

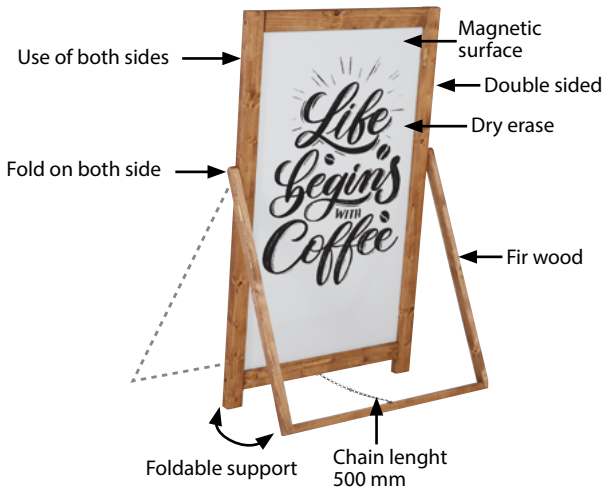

TECHNICAL DRAWING

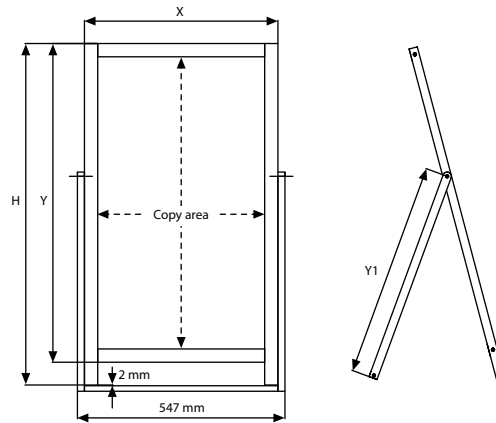

ARTICLES

ARTICLE	EXTERNAL (x-y)	COPY AREA	H	Y1	DESCRIPTION	WEIGHT	PACKING SIZE
						WITH PACKING	*W X H X D
UWDFS0D010	510 X 840 mm	440 X 770 mm	900 mm	566,5 mm	Dark Wood	3,900 kg	600 X 970 X 45 mm
UWDFS0D020	510 X 1090 mm	440 X 1020 mm	1150 mm	701,5 mm	Dark Wood	4,650 kg	600 X 1220 X 45 mm
UWDFS0D030	510 X 1140 mm	440 X 1370 mm	1500 mm	866,5 mm	Dark Wood	5,900 kg	600 X 1570 X 45 mm

OPTIONAL ACCESSORIES



Optional magnetic buttons. Packed in 10. UYUP397000



Colour chalkboard marker. 10 mm wide. 5 Pcs. / UYAKLM1251



White chalkboard marker for Wood Display. 10 mm wide. 3 Pcs / UYAKLM1250



Magnetic PET Cover
Please don't forget to order

MAGNETIC PET COVER		
ARTICLE	SIZE	COLOUR
UPCMOR00A4	210 X 297 mm	Red
UPCMOB00A4	210 X 297 mm	Black
UPCMOW00A4	210 X 297 mm	White
UPCMOG00A4	210 X 297 mm	Grey
UPCMOG00A5	105 X 148 mm	Grey
UPCMOB00A5	105 X 148 mm	Black



T: +90 850 433 67 85 / info@mtdisplays.com / www.mtdisplays.com

PHYSICAL DATA

Material

Double sided solid fir wood profile frame and support with lacquered finish, double sided magnetic white dry-wipe chalkboards.

Surface Finish

Natural beech wood frames with lacquered finish and magnetic white dry-wipe chalkboards in standard.

Warranty

All products are guaranteed for 1 years by MT Displays with below conditions:

[Warranty Conditions](#)

Storage Conditions

Goods should be stored at 0° to 25°C in a dry place. Store in the original package.

Installation Considerations

Packed unassembled in a single box with an easy-to-understand instruction sheet. Assembly in 10 seconds. One set includes a double sided solid fir wood profile frame with lacquered finish for long term use and wood support foldable on both sides, double sided magnetic white dry-wipe chalkboards for changing notes easily, chain for keeping the system stable. Foldable support can be used on both sides. Easy to carry by folding the support, and saving space in storage. Magnetic PET covers and magnetic buttons are optional, not included in standard package. Please order separately. Suitable for using chalkboard water-based pen. Chalkboard pens are not included in the original pack, should be ordered separately. No-ghost after cleaning. For spotless removing of chalk pens from surface, please use window & glass cleaner otherwise clean with damp cloth.

Design Considerations

Double-sided, free-standing sidewalk signs with foldable support, designed for writing on with waterbase markers. A perfect way to present removable messages, announcements or promotions to your audience while keeping them updated. Suitable for INDOOR use with 440x770mm, 440x1020mm and 440x1370mm writing areas.

Cleaning and Disinfecting

Clean your displays, with damp microfiber clothes, rinsed with simply water or warm, soapy or gentle shampooed water. Avoid using vinegar, abrasive, acidic, alcohol-based or heavy cleaners or cleaners containing Ammonia. Only after cleaning the product, if needed, simply apply disinfectant or sanitizer that is in compliance with your local guidelines and regulations.

This technical sheet's contents are all subject to update and modification at MT Displays' exclusive discretion. There is nothing official about this document. For final and legally binding information, please get in touch with the sales staff at MT Displays.



T: +90 850 433 67 85 / info@mtdisplays.com / www.mtdisplays.com