

## ZICK-ZACK



### SINGLE OR DOUBLE LEG BROCHURE HOLDERS WITH ACRYLIC SHELVES

Decorative legs are made of silver anodised aluminum ellipse profile, shelves are made of 10 mm acrylic. Metallic powdercoated base is made up of 8 mm aluminium or metallic powder coated base.

#### KEY SELECTION ATTRIBUTES

- \* Single Leg or Double Leg, double-sided, free standing Brochure Holders with zick-zack designed acrylic shelves for keeping minimum 6 brochures at the same time.
- \* Suitable for INDOOR public spaces with brochure holding capacity of 6x A4 in standard.
- \* One set includes transparent shelves made of acrylic with 10mm thickness and 225mm width, 25x51 mm anodised aluminium ellipse profile main body, 420x300mm RAL 9006 powder coated base with 2,70 kg weight for stability, screws, screw cups and allen key for fixing.

- \* Header with snap open profile is included in standard package of single leg with header and double leg versions. Header can not be ordered separately.
- \* Easy to change header logo & message. Heavy stable base is suitable for public spaces. Use the hole caps in the hardware set to cover the mounting holes.
- \* Natural silver-anodized main body and RAL 9006 powder coated base in standard and various RAL colors available with antimicrobial powder coating.
- \* The product is packed unassembled in 2 boxes with an easy-to understand instruction sheet & fixing elements. See info chart for pack sizes.

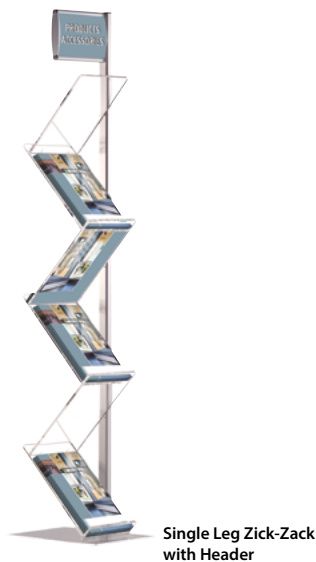

## COLOURS IN STOCK



Silver

## SUITABLE FOR

Zick-Zack Sets can be used for INDOOR applications, for displaying brochures in many locations like shopping centers, markets, groceries, hotels, offices airports, shops and stores, hospitals, schools, apartments, restaurants, halls, meeting rooms, gas stations and many more.

## FEATURES



## EXPLODED VIEW

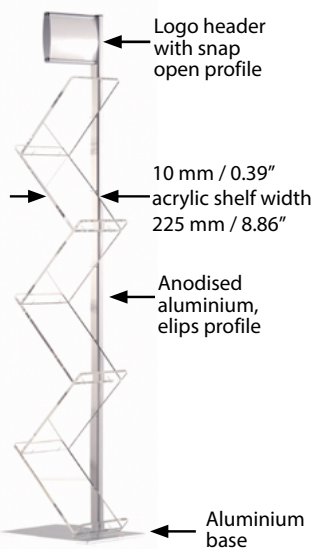

## TECHNICAL DRAWING

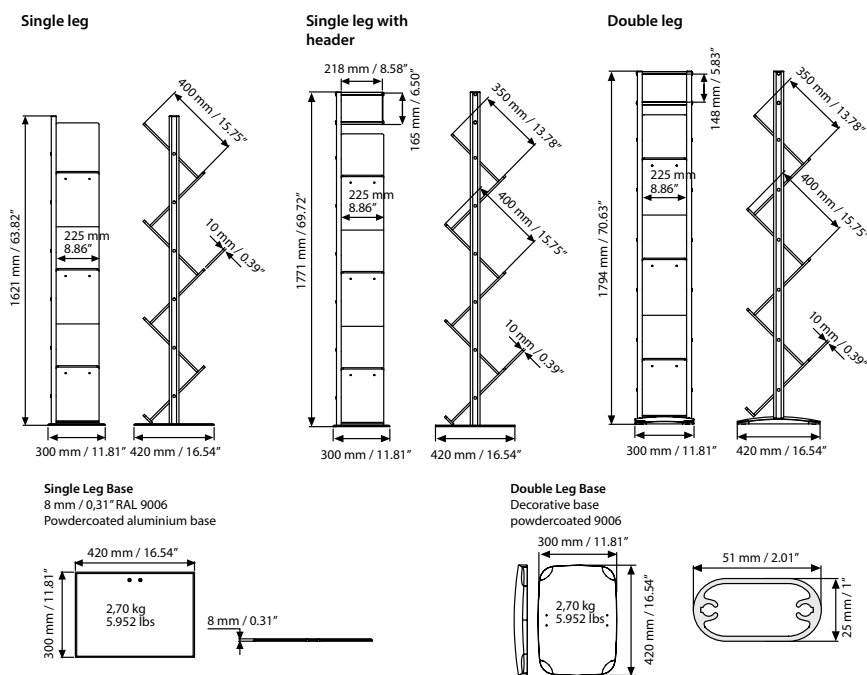

## ARTICLES

ARTICLE	MODELS	CAPACITY	WEIGHT			PACKING SIZE		
			WITH PACKING	SHELF & BASE	ELIPS PROFILE	WITH PACKING	SHELF & BASE	ELIPS PROFILE
UZZTAC1001	Single leg	6 X A4	11,350 kg	330 X 440 X 130 mm	70 X 1670 X 50 mm			
UZZTAC1002	Single leg with header	6 X A4	11,500 kg	330 X 440 X 130 mm	70 X 1820 X 50 mm			
UZZCAC1002	Double Leg	6 X A4	13,350 kg	330 X 440 X 170 mm	70 X 1820 X 70 mm			

## PHYSICAL DATA

### Material

Acrylic shelves, 25x51mm aluminium profile main body and base.

### Surface Finish

Natural silver-anodized main body and RAL 9006 powder coated base in standard and various RAL colors available with antimicrobial powder coating. Call for custom color requests.

### Storage Conditions

Goods should be stored at 0° to 25°C in a dry place. Store in the original package.

### Recycled Content

Up to 78% recycled content used.

### Warranty

All products are guaranteed for 3 years by MT Displays with below conditions:

[Warranty Conditions](#)

### Installation Considerations

Zick-Zack is packed unassembled in 2 boxes with an easy-to understand instruction sheet & fixing elements. See info chart for pack sizes. One set includes transparent shelves made of acrylic with 10mm thickness and 225mm width, 25x51 mm anodised aluminium ellipse profile main body, 420x300mm RAL 9006 powder coated base with 2,70 kg weight for stability, screws, screw cups and allen key for fixing. Header with snap open profile is included in standard package of single leg with header and double leg versions. Header can not be ordered separately. Easy to change header logo & message. Heavy stable base is suitable for public spaces. Use the hole caps in the hardware set to cover the mounting holes.

### Cleaning and Disinfecting

Clean your displays, with damp microfiber clothes, rinsed with simply water or warm, soapy or gentle shampooed water. Avoid using vinegar, abrasive, acidic, alcohol-based or heavy cleaners or cleaners containing Ammonia. Only after cleaning the product, if needed, simply apply disinfectant or sanitizer that is in compliance with your local guidelines and regulations.

### Design Considerations

Single Leg or Double Leg, double-sided, free standing Brochure Holders with zick-zack designed acrylic shelves for keeping minimum 6 brochures at the same time. Suitable for INDOOR public spaces with brochure holding capacity of 6x A4 in standard.



T: +90 850 433 67 85 / info@mtdisplays.com / www.mtdisplays.com

# INSTALLATION INSTRUCTIONS

Zick-Zack / 1001920

**Each product includes**

- Elips profile No: 1 x 1 pcs
- Aluminium base No: 2 x 1 pcs
- Acrylic shelf No: 3 x 1 pcs
- Acrylic shelf No: 4 x 3 pcs
- Acrylic shelf No: 5 x 2 pcs
- Acrylic shelf stopper No: 6 x 1 pcs
- Screw cups No: 7 x 6 pcs
- Screw No: 8 x 2 pcs
- Screw No: 9 x 18 pcs
- Allen key No: 10 x 1 pcs

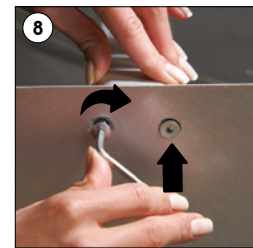
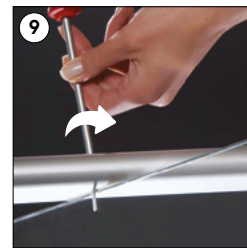
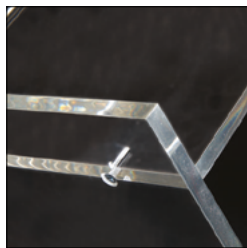
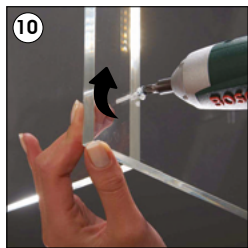
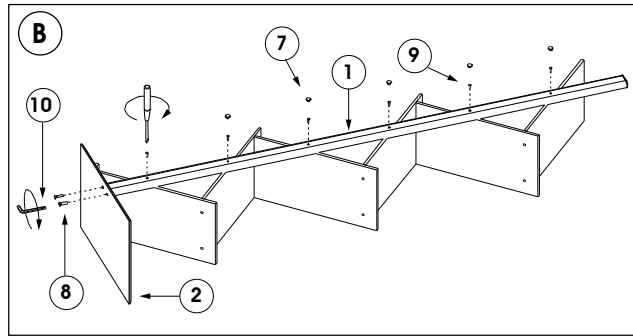
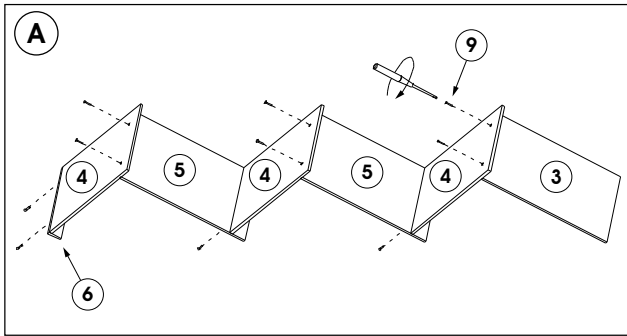
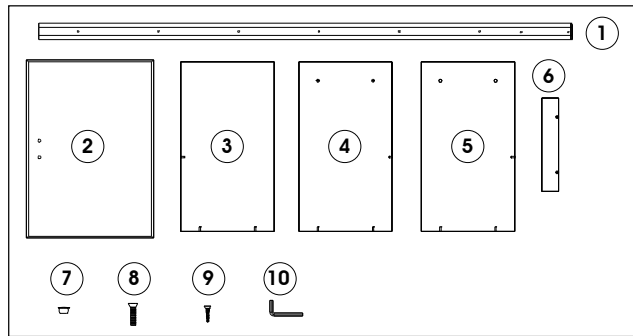

•Please do not tighten the screws too much to prevent the plastic washers to be deformed or broken. In case they are broken, it will be impossible to fix the plastic screw cup



- Please inform the order number on the product or on the carton (e.g. 1/110001394-460) to the place that you have made the purchase if any problem with the product occurs.
- All rights reserved. All pictures, figures and writings are secured internationally by copy-right law. Infringements will be sued by civil and legal law.



# INSTALLATION INSTRUCTIONS

## Zick-Zack with Header / 1001921

### Each product includes

•Elips profile	No: 1 x 1 pcs	•Screw caps	No: 12 x 2 pcs
•Aluminium base	No: 2 x 1 pcs	•Elips profile	No: 13 x 2 pcs
•Acrylic shelf	No: 3 x 1 pcs	•Allen key	No: 14 x 1 pcs
•Acrylic shelf	No: 4 x 3 pcs	•Aluminium plate	No: 15 x 1 pcs
•Acrylic shelf	No: 5 x 2 pcs		
•Acrylic shelf stopper	No: 6 x 1 pcs		
•Screw cups	No: 7 x 8 pcs		
•Screw	No: 8 x 2 pcs		
•Screw	No: 9 x 18 pcs		
•Screw	No: 10 x 4 pcs		
•Screw cups	No: 11 x 2 pcs		

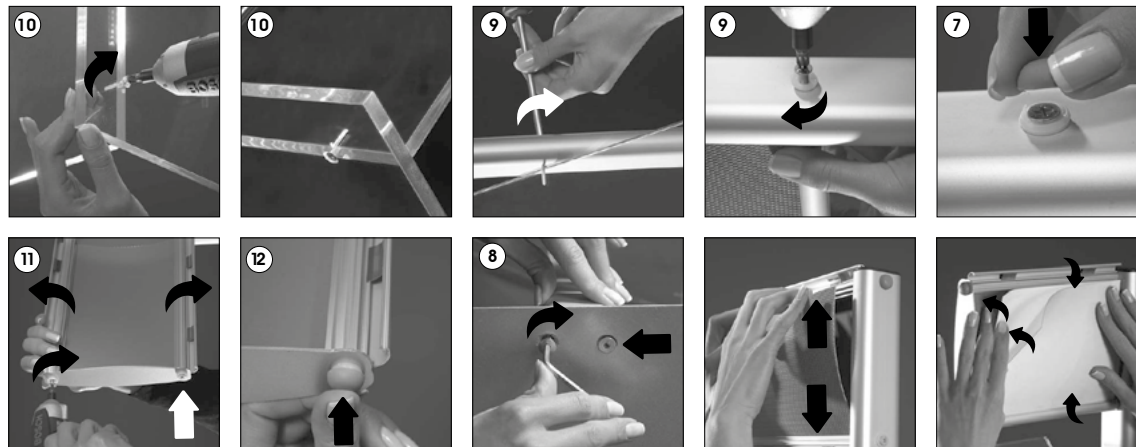
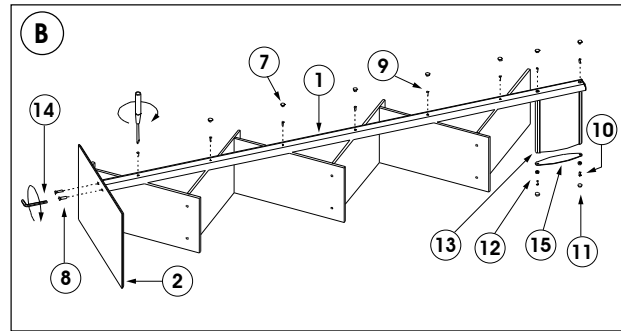
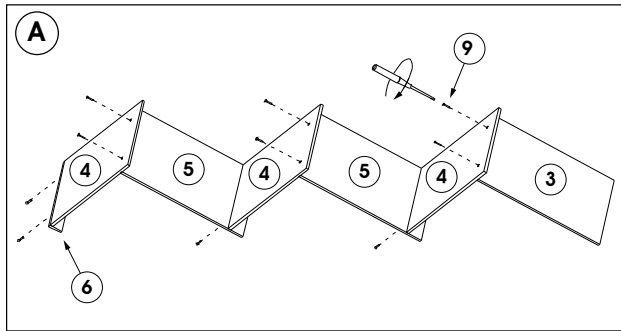
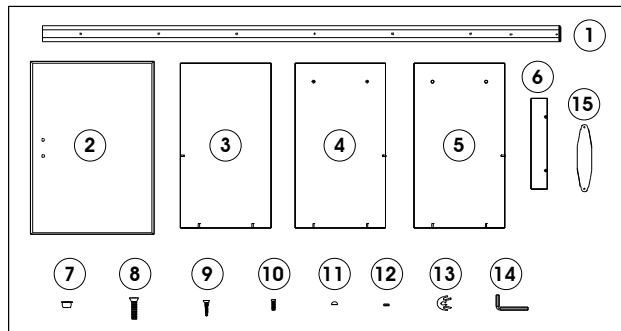

•Please do not tighten the screws too much to prevent the plastic washers to be deformed or broken. In case they are broken, it will be impossible to fix the plastic screw cups.

• Please inform the order number on the product or on the carton (e.g. 1/110001394-460) to the place that you have made the purchase if any problem with the product occurs.  
 • All rights reserved. All pictures, figures and writings are secured internationally by copy-right law. Infringements will be sued by civil and legal law.



# INSTALLATION INSTRUCTIONS

## Double Leg Zick-Zack / 1001922

### Each product includes

•Elips profile	No: 1 x 2 pcs
•Aluminium base	No: 2 x 1 pcs
•Acrylic shelf	No: 3 x 1 pcs
•Acrylic shelf	No: 4 x 5 pcs
•Acrylic shelf stopper	No: 5 x 1 pcs
•Screw	No: 6 x 24 pcs
•Screw cups	No: 7 x 16 pcs
•Screw	No: 8 x 4 pcs
•Aluminium profile	No: 9 x 2 pcs
•Screw	No: 11 x 4 pcs
•Allen key	No: 12 x 1 pcs

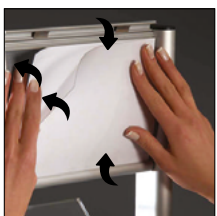
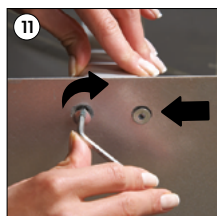
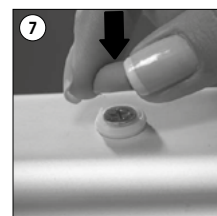
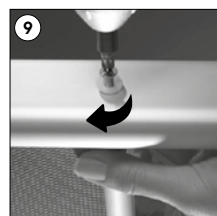
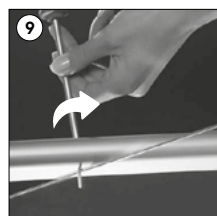
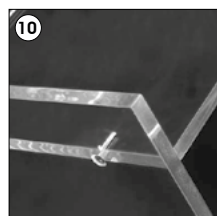
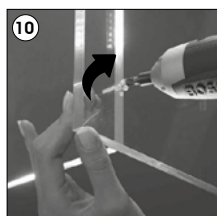
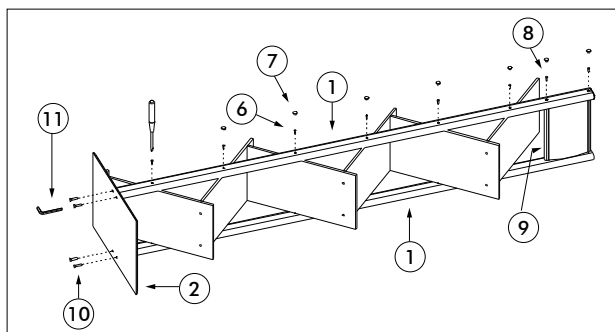
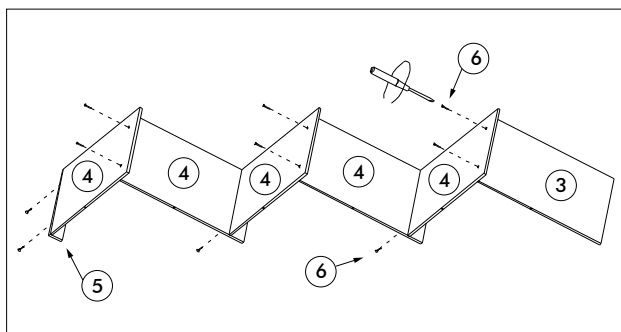
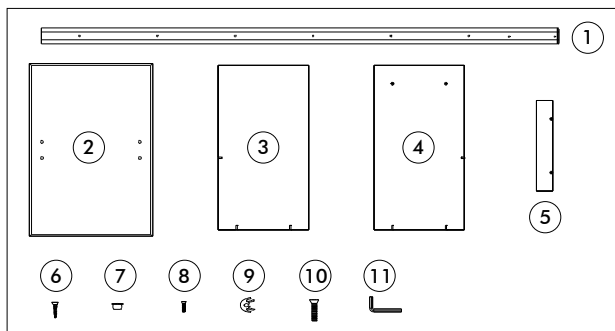

•Please do not tighten the screws too much to prevent the plastic washers to be deformed or broken. In case they are broken, it will be impossible to fix the plastic screw cups.

• Please inform the order number on the product or on the carton (e.g. 1/110001394-460) to the place that you have made the purchase if any problem with the product occurs.  
 • All rights reserved. All pictures, figures and writings are secured internationally by copy-right law. Infringements will be sued by civil and legal law.



This technical sheet's contents are all subject to update and modification at MT Displays' exclusive discretion. There is nothing official about this document. For final and legally binding information, please get in touch with the sales staff at MT Displays.



T: +90 850 433 67 85 / info@mtdisplays.com / www.mtdisplays.com