

WINDPRO GO



ECONOMICAL SIDEWALK SIGN SUITABLE FOR THE MOST POPULAR POSTER SIZE

WindPro Go is heavy and robust waterbase pavement sign for outdoor and indoor use. It consists of 2 main articles: frame and the base. No sharp edges and has steel springs for flexibility. Poster use is double sided. Recommended to use with foil posters.

KEY SELECTION ATTRIBUTES

- * Double-sided Pavement Sign with swinging steel spring design for flexibility and stability.
- * Practical, portable, user-friendly and economic.
- * Patent protected (EUIPO / 015069741-0001, 015069741-0002, 015069741-0003; 015069741-0004) WindPro Go is heavy and robust pavement sign with 2 main parts: frame and the water base.
- * OUTDOOR FRIENDLY & WIND RESISTANT: Suitable for windy outdoor conditions. This product is not waterproof, but suitable for both outdoor and indoor conditions. For outdoor use, it is recommended to use with foil posters.
- * Easy and quick poster change with snap-open frame design. Suitable for most popular A1 poster size. Suitable for silk screen printing, max. letter height on frame is 28mm and printing area on base is 300x80(h)mm.
- * One set includes a double sided snap open 33 mm aluminium profile swing frame with 27mm depth and soft corners for safety, 2 anti-reflex PET

- poster covers, 1 strong PP backing, heavy water base with 2 wheels for easy transportation and fixing set for installation.
- * Ground wheels enable easy movement of the product. It is recommended to carry the product with a carry tool, when the base is full with water. Carry tool is optional, not included in package, should be ordered separately.
- * Blow molded HDPE base is suitable up to use -20°C. Heavy water base provides stability. Base weight 3,5kg. Water capacity 19lt. Base weight when filled with water 22,5kg.
- * Natural silver-anodized, black in standard and various RAL colors available with antimicrobial powder coating. Waterbase standard in dark grey color or black, other colors are available upon request.
- * Packed in 2 boxes with an easy mounting instruction sheet & fixing set. Assembly in 40-50 seconds.



COLOURS IN STOCK

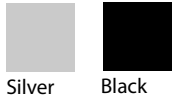

Silver Black

COLOUR OPTIONS

Black Anodised

Red- RAL 3020

Silver Anodised

SUITABLE FOR

Windpro Go can be used for INDOOR and OUTDOOR applications, for signage needs in many locations like shopping centers, markets, groceries, hotels, offices airports, shops and stores, hospitals, schools, apartments and many more.

WATCH VIDEO



Watch video at our website
www.mtdisplays.com

FEATURES



Water Capacity 19lt



2 Wheels



Safe Corners



Antiflex Pet Protection



Steel Spring

EXPLODED VIEW

632 mm



879 mm

Wheels

Optional carry tool.
UYUP480945

TECHNICAL DRAWING

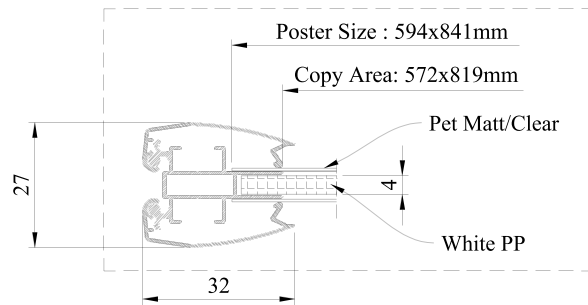
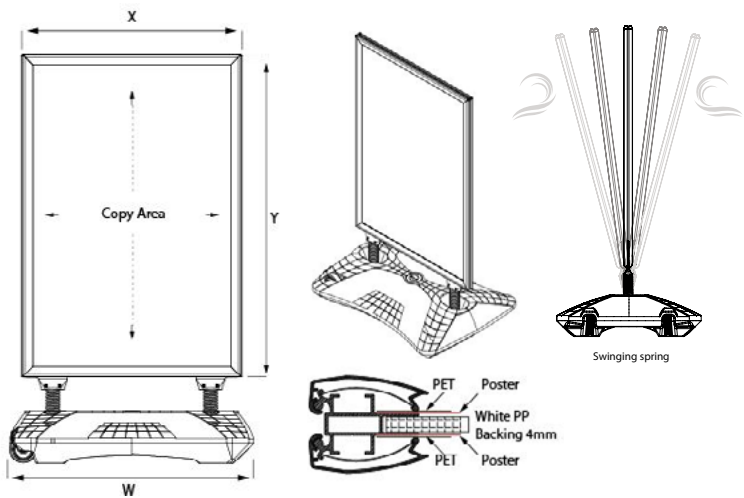

ARTICLES

SILVER	BLACK	EXTERNAL	POSTER	COPY	H	W	D
USWPG00N24	USWPG00B24	648 X 953 mm	610 X 915 mm	588 X 893mm	1207 mm	720mm	530 mm
USWPG00NA1	USWPG00BA1	632 X 879 mm	594 X 841 mm	572 X 819 mm	1133 mm	720 mm	530 mm

WEIGHT	PACKING SIZE
WITH PACKING	*W X H X D
8,70 kg	670 X 1040 X 45mm / 560 X 740 X 175 mm
8,42 kg	660 X 960 X 45 mm / 560 X 740 X 175 mm



T: +90 850 433 67 85 / info@mtdisplays.com / www.mtdisplays.com

PRINT TEMPLATES

Easy Go A Board - A1

Document Size: 604 x 851 mm (Includes Bleeds)

Finished Size: A1 (594 x 841 mm) [Print](#)

Easy Go A Board - 24" x 36"

Document Size: 24.4" x 36.4" (Includes Bleeds)

Finished Size: 24" x 36" (609.6 x 914.4 mm) [Print](#)

PHYSICAL DATA

Material

33mm aluminium profile snap open swing frame, PET anti-reflex poster cover, PP backing and blow molded HDPE base.

Poster Material & Thickness

Recommended to use foil posters. 0,10 – 0,20 mm for standard product. Max poster thickness is 2 mm for low density rigid posters such as PVC foam, PP, etc. Any non-standard poster thickness should be indicated with order.

Surface Finish

Natural silver-anodized, black in standard and various RAL colors available with antimicrobial powder coating. Base standard in dark grey color or black, other colors are available upon request. Call for custom color requests.

Recycled Content

For frame part up to 78% and for base part up to 40% recycled content used.

Warranty

All products are guaranteed for 3 years by MT Displays with below conditions:

[Warranty Conditions](#)

Installation Considerations

WindPro Go is packed 2 boxes with an easy mounting instruction sheet & fixing set. Assembly in 40-50 seconds. One set includes a double sided snap open 33 mm aluminium profile swing frame with 27mm depth and soft corners for safety, 2 anti-reflex PET poster covers, 1 strong PP backing, heavy water base with 2 wheels for easy transportation and fixing set for installation. Ground wheels in upside position enable easy movement of the product. It is recommended to carry the product with a carry tool, when the base is full with water. Carry tool is optional, not included in package, should be ordered separately.

Storage Conditions

Goods should be stored at 0° to 25°C in a dry place. Store in the original package.

Cleaning and Disinfecting

Clean your displays, with damp microfiber clothes, rinsed with simply water or warm, soapy or gentle shampooed water. Avoid using vinegar, abrasive, acidic, alcohol-based or heavy cleaners or cleaners containing Ammonia. Only after cleaning the product, if needed, simply apply disinfectant or sanitizer that is in compliance with your local

guidelines and regulations.

Design Considerations

Double-sided Pavement Sign with swinging steel spring design for flexibility and stability. Practical, portable, user-friendly and economic. Patent protected (EUIPO / 015069741-0001, 015069741-0002, 015069741-0003; 015069741-0004) WindPro Go is heavy and robust pavement sign with 2 main parts: frame and the water base. OUTDOOR FRIENDLY & WIND RESISTANT: Suitable for windy outdoor conditions. This product is not waterproof, but suitable for both outdoor and indoor conditions. For outdoor use, it is recommended to use with foil posters. Easy and quick poster change with snap-open frame design. Suitable for most popular A1 poster size. Suitable for silk screen printing, max. letter height on frame is 28mm and printing area on base is 300x80(h)mm. Blow molded HDPE base is suitable up to use -20°C. Heavy water base provides stability. Base weight 3,5kg. Water capacity 19lt. Base weight when filled with water 22,5kg.



INSTALLATION INSTRUCTIONS

Windpro Go / 1009758H000



• Please inform the order number on the product or on the carton (e.g. 1/110001394-460) to the place that you have made the purchase if any problem with the product occurs.

• All rights reserved. All pictures, figures and writings are secured, internationally by copy-right law. Infringements will be sued by civil and legal law.

